

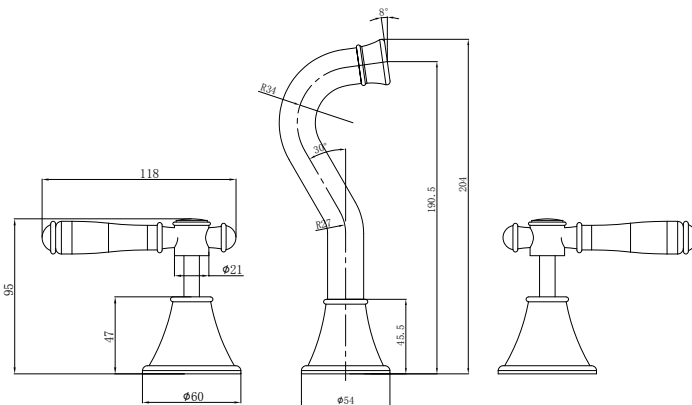

Available in



PCK90NZ01-BN
Brushed Nickel



PCK90NZ01-BG
Brushed Gold



PCK90NZ01-MB
Matt Black



PCK90NZ01A-BN
Brushed Nickel



PCK90NZ01A-BG
Brushed Gold



PCK90NZ01A-MB
Matt Black



PCK90NZ01A
Chrome

Clasico Bath Set

PCK90NZ01

Information

- Finish: Chrome
- Material: Brass /Ceramic
- Operating temperature 1°C to 70°C
- Operating pressure 150~500 kPa
- Germany Neoperl Aerator
- 1/4 Turn Ceramic Spindles
- WELS: 5 Star 5.5L/min (T41843)

Maintenance and Care

- Do not use harsh detergents or products that contain chloride & halides.
- Do not use abrasive, cream or citrus based cleaners or hydrochloric acid.
- Surface should be cleaned only with a mild detergent that must be rinsed off.
- It is suggested to only clean with warm water and a soft cloth.
- Damage caused by the wrong cleaning methods used will void warranty.

Please visit <https://www.aclco.com.au/warranty.html> to view the full warranty